

PRODUCT CATALOGUE

JFC Corporation

Manufacturing & Sales Products

✓ **Filtration Equipment**

- Filtration System Engineering
- Metallic Filter :
 - Multi-Layer sintered, Fiber metal sintered,
Powder metal sintered
- Cartridge Filter :
 - Wound Depth Cartridge, Resin Bonded Fiber Cartridge,
Binder-free Cartridge, Pleated Paper Cartridge,
Metallic Cartridge (Cylindrical & Pleated Type),
Membrane Cartridge
- Candle Filter
- Bag Filter
- Activated Carbon Filter System

✓ **Coalescer / Separator**

- Liquid-liquid Coalescer
- Liquid-gas Coalescer
- Oily Water Separator

✓ **Mist Eliminator**

- Vane Type Eliminator
- Pad/demister Type Eliminator
- Cartridge Type Eliminator

✓ **Strainer**

- Forged Strainer
- Casting Strainer
- Steel Welded Strainer

JFC Model Category

No.	Section	Model No.	Detailed Item
1	Metallic Filter Cartridge	PS : 1	Powder Sintered
		MS : 2	Multi-Layer Sintered
		FS : 3	Fiber Sintered
		WS : 4	Woven Wire Screen
2	Disposable Cartridge	JD : 5~7	Disposable Cartridge
3	Coalescer / Separator	LLC, GLC	Coalescer / Separator
		MME, STV, DPV	Mist Eliminator
		EOQ	Inlet Diffuser
4	Filter System	JW	Activated Carbon Filter System
		-	Auto Control Filter System
		JA-B	Brush Cleaning Type, Auto-Cleaning Strainer
		JA-R	Rotating Arm Type, Auto-Cleaning Strainer
5	Strainer	JS-B	Bucket Type Strainer
		JS-Y	Y-Type Strainer
		JS-T	Tee Type Strainer
		JS-C	Temporary Strainer
		JS-D	Duplex Type Strainer

Basic Check Point When Designing Filter

✓ **Filter Housing Material**

- Carbon Steel, Stainless Steel 304, 316, Hastelloy, Nickel Alloy and etc.

✓ **Applicable Design Code**

- ASME Sec. VIII Div.1

✓ **Cover Opening Type**

- Stud Bolt & Nut with Davit
- Swing Bolt & Eye Nut with Hinge or Davit
- Quick Opening Closure
- Hydraulic Cover Lift

✓ **Operation Condition (Minimum information when ordering)**

- Design Pressure : Kg/cm².G, psid, bar-g, etc.
- Operating Pressure : Kg/cm².G, psid, bar-g, etc.
- Design Temperature : °C, °F
- Operating Temperature : °C, °F
- Flow Rate : m³/hour, gpm, cfm, etc.
- Filtration Rating : μm, #mesh, mm, inch, etc.
- Fluid Name : Water, Oil, Compressed Air, Hydrogen Amine, etc.
- Specific Gravity or Density : kg/m³, kg/liter, etc.
- Connection Size & Rating : ASME, AWWA, MSS, API, etc.
- Operating Mode : Batch or continuous
- Purpose to use filter
- Pollution concentration

Check Point When Selecting Filter

✓ Initial Pressure Drop

- The lower initial pressure drop, the longer change cycle of element
(The optimum design must be considered the comparison of Economic Efficiency of some costs for initial installation, maintenance and repair.)

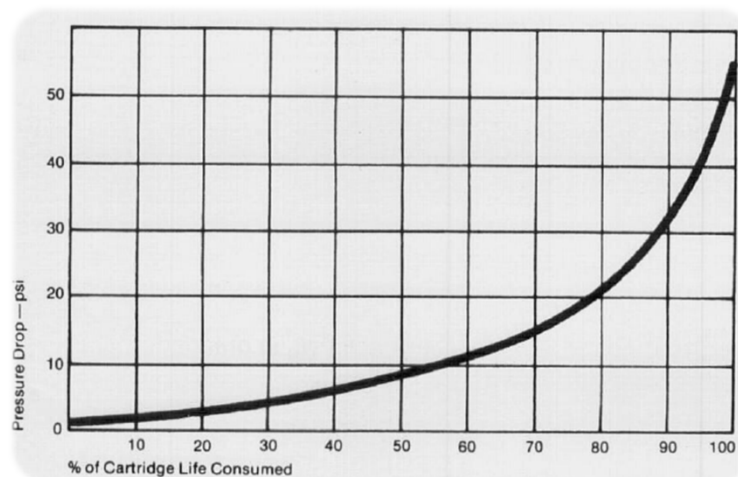

✓ Removal Rating of Element

- According to use purpose, as there are various elements, it must be selected whether pollution particle is nominal rating or absolute rating. In case of the same shape, the relative superiority become clear comparing Beta Ratio

✓ Five points of performance decision of filter is simply summarized in the following Darcy's law

A : filtration area

Q : Flow rate

ΔP : Pressure Drop

μ : Viscosity

R : Media Resistance

$$Q = \frac{\Delta P \times A}{\mu \times R}$$

FILTER CARTIDGE

JFC Corporation

Metallic Filter Cartridge



✓ **Advantages of JFC Metallic Filter Cartridge**

- It is advantageous in the side of life and protection of Environment as it is possible to re-use after cleaning or reverse cleaning comparing existed cartridge
- It is beneficial in the super-low temperature, high temperature and high pressure
- It maintains absolute ratio of filtration
- The ratio of porous is very high
- Pressure loss is very low

✓ **The use ranges of JFC Metallic Filter Cartridge**

- Filtration of process for nuclear power generation and industry
- Filtration of process for petrochemical and refinery
- Filtration of gas and operating of oil pressure

Ordering Information

JC 1 C 010 – 30 – SO
1 2 3 4 5 6

1	JFC Code	JC : Cleanable JD : Disposable
2	Media Form	JC-1 : Powder Sintered JD-5 : Wound JC-2 : Multi-Layer Woven Wire Sintered JD-6 : Pleated JC-3 : Fiber Metal Sintered JD-7 : Bag JC-4 : Woven Wire Screen
3	Cartridge Type	C : Cylindrical P : Pleated
4	Removal Grade	Model No. according to Series
5	Cartridge OD/Length	10 : 10" (OD : 2.5") 20 : 20" (OD : 2.5") 30 : 30" (OD : 2.5") 40 : 40" (OD : 2.5") 436 : 36" (OD : 4.5")
6	End Connection	DO : Double Open Ends SO : Single Open End NPT : NPT Single Open End

PS Series

Filter Cartridge for Powder Metal Sintered Powder Sintered Media

Porous media is produced by diffusional sintered bond of powder metal

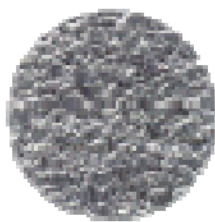

0.2µm



0.5µm



5 µm



20 µm



100 µm

100X views of standard micron grades

Powder Sintered Medium

Liquid Rating : 2 micron absolute

Porosity : 35%

Flow (H₂O) : 2gpm/ft² at 0.5 psid

Contaminant Capacity : 0.7g/ft² at 0.5 psid



Feature

- Porousness is uniformed as it becomes sintered forming with regular particle
- Filtration efficiency is high because it is depth type to pile up pollution material in the twisted windingly flow passage
- Durability and conservation capacity for filtration particle of medium is excellent as it is formed by the sintered method of powder metal
- It can be used in lots of usage as it produced by various material, 304LSS, 316LSS, Inconel, Monel, Hastelloy, Alloy 20, and Titanium and etc. to have excellent corrosion resistance
- It is semi-permanent and regeneration effect is high with reverse-cleaning and supersonic cleaning method as the washing rate is excellent with high washing rate
- The application limit of temperature is wide range from super-low-temperature to high-temperature of 926 °C
- It can endure the high-pressure-drop and can be applied to high pressure as it has high burst and collapse pressure

Type	Model No.	Removal Rating (µm)			
		Liquid		Gaseous	
		Nominal	Absolute	Nominal	Absolute
Cylindrical	PS 0002	0.2	2	0.01	0.1
	PS 0005	0.5	5	0.1	0.5
	PS 0020	2	9	0.5	1
	PS 0050	5	13	1	1.5
	PS 0100	10	20	2	3
	PS 0200	20	35	5	10
	PS 0400	40	55	10	20
	PS 1000	100	120	30	50

Filter Cartridge for Multi-Layer Metal Sintered Multi-Layer Sintered Media

This media is produced through Multi-Layer Diffusion Sintered Bond of Woven Wire Screen to be woven by metal wire in order of support layer, distribution layer, filtration layer and protection layer

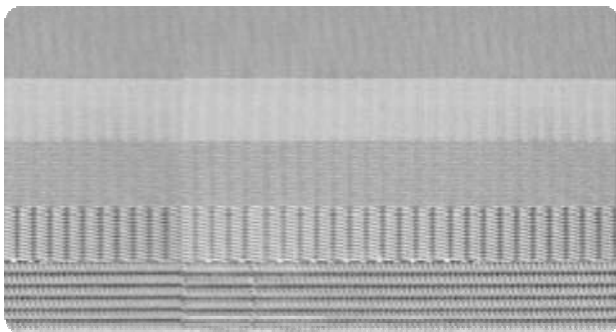

PROTECTION LAYER

FILTRATION LAYER

DISTRIBUTION LAYER

SUPPORT LAYER

SUPPORT LAYER

Feature

- It is a metal net to be weaved at regular intervals and maintains the uniform pore, as it became sintered forming
- The choice range of filtration granularity is wide
- Media production is possible as it adjusted the join order of metal net according to usage
- Treatment is easy and there is no need for a supporting or reinforcing structure as it is solid
- It is advantageous in an application of high-temperature and corrosion resistance is excellent as it is made by a raw material such as 304SS, 304LSS, 316SS, 316LSS
- It can endure a high-pressure-drop and is advantageous to a high-pressure as it has a high-burst and a collapse pressure
- It is semi-permanent and regeneration effect is high with a super sonic wash or reverse-wash

Woven Wire Cloth Laminate

Liquid Rating : 10 micron absolute

Porosity : 35%

Flow (H₂O) : 2gpm/ft² at 0.5 psid

Contaminant Capacity : 0.7g/ft² at 0.5 psid

Type	Model No.	Removal Rating (µm)			
		Liquid		Gaseous	
		Nominal	Absolute	Nominal	Absolute
Cylindrical	MS 002A	2	10	0.5	1
	MS 005A	5	13	1	1.5
	MS 010A	10	17	1.5	2
	MS 015A	15	25	3	5
	MS 025A	25	40	6	12
	MS 033A	33	55	9	18
	MS 044A	44	70	20	40
	MS 061A	61	100	100	85
	MS 074A	74	120	120	90
	MS 104A	104	150	150	120
	MS 140A	140	200	200	175

WS Series

Filter Cartridge for Woven Wire Screen

Woven Wire Screen Media

It has feature and merit of each form and there are woven wire screen of various type according to weaving method of a metal wire as following pictures

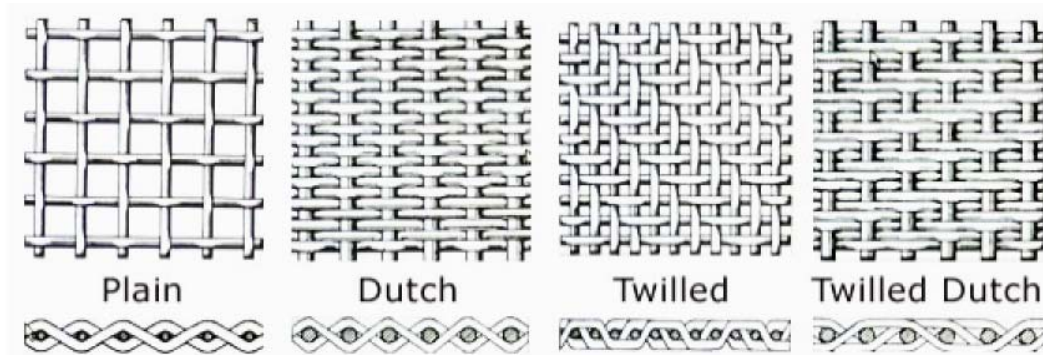

- Types of weaves -

Woven Wire Screen

Liquid Rating : 12 micron absolute
 Porosity : 60%
 Flow (H₂O) : 8gpm/ft² at 0.5 psid
 Contaminant Capacity : 2.2g/ft² at 0.5 psid

Type	Model No.	Removal Rating (μm)			
		Liquid		Gaseous	
		Nominal	Absolute	Nominal	Absolute
Cylindrical, Pleated	WS 005	5	12	5	10
	WS 010	10	17	10	15
	WS 020	20	25	20	20
	WS 035	35	48	35	40
	WS 045	45	58	45	50
	WS 060	60	73	60	65
	WS 075	75	95	75	80
	WS 100	100	120	100	90
	WS 250	250	275	250	200

Filter Cartridge for Fiber Metal Sintered

Media for Fiber Metal Sintered

This media is produced by Diffusional Sintered Bond with a mat type of a fiber metal of delicate denia

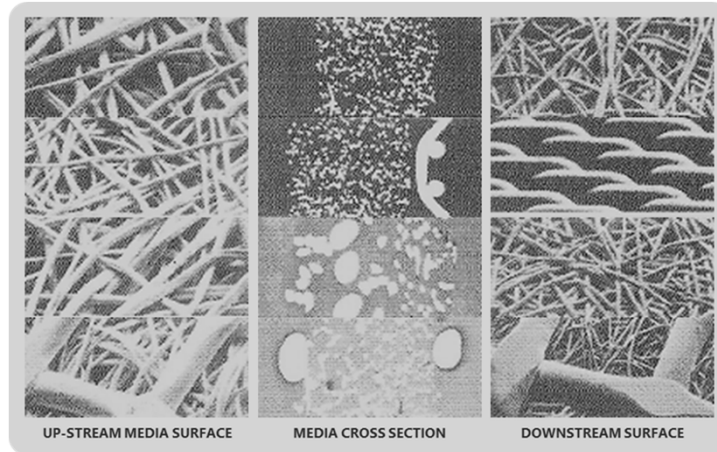

Feature

- Filtration effect is high as a fiber metal of delicate denia type is sintered
- Conservation ability of filtration particle is excellent
- Life time is long as a heaping capacity for pollution material is big
- Cartridge production of pleated type is possible as the material thickness is thin
- Application Range of fluid and gas is wide and the corrosion resistance is excellent as it possible to produce by various materials such as 304LSS, 316LSS, Inconel, Monel, Hastelloy, Alloy 20, and Titanium and etc.
- It is semi-permanent and regeneration effect is high with a super-sonic wash or reverse-wash as permeability is high and wash is excellent

Fiber Metal Medium

Liquid Rating : 3 micron absolute

Porosity : 60%

Flow (H₂O) : 8gpm/ft² at 0.5 psid

Contaminant Capacity : 2.2g/ft² at 0.5 psid

Type	Model No.	Removal Rating (μm)			
		Liquid		Gaseous	
		Nominal	Absolute	Nominal	Absolute
Cylindrical, Pleated	FS 001	1	3	0.3	1
	FS 003	3	5	0.6	1.7
	FS 005	5	10	1	2.9
	FS 010	10	15	3	9
	FS 025	25	35	8	19
	FS 030	30	40	10	30
	FS 070	70	105	100	85
	FS 140	140	225	200	150

JD Series

Disposable Cartridge

Application

- General process industry
- Petrochemical industry
- Chemical industry



JD-5 : Wound type Cartridge

Wound type cartridge for traditional depth filtering.
Filter media supplied as: Cotton, Cellulose, Polyester,
Polypropylene, Micron Fiber-glass.

JD-6 : Pleated type Cartridge

JD-P cartridges are pleated liquid filtration elements designed for applications with large flow and contaminant requirements.

Filter media supplied as: Cotton, Cellulose, Polyester,
Polypropylene, Micron Fiber-glass.

JD-7 : Bag type Cartridge

Filter media supplied as: Nomex fabric, Nylon fabric,
Polyester fabric, or Polypropylene fabric.

COALESCER/SEPARATOR

JFC Corporation

Coalescer / Separator

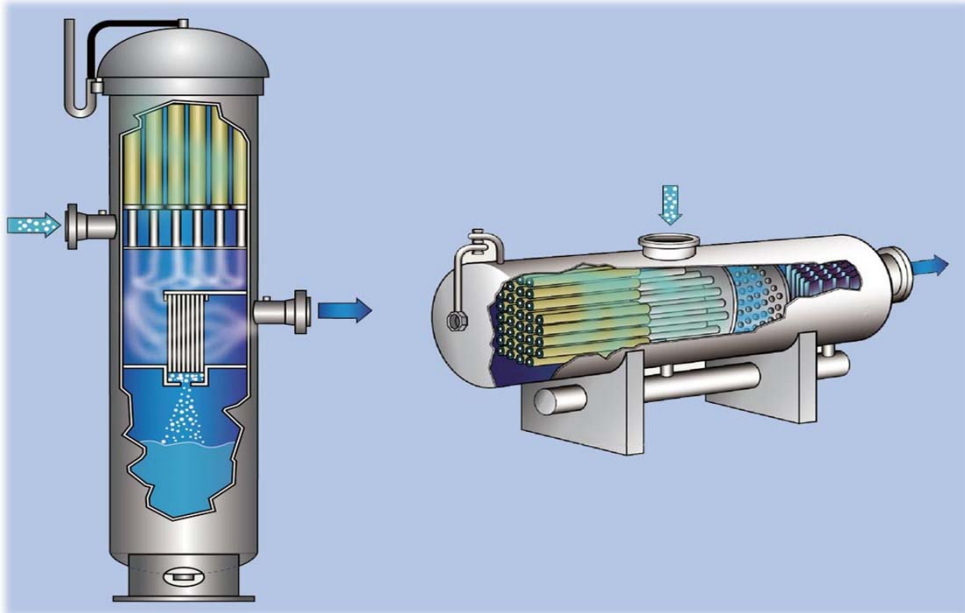

Coalescer/Separator is an equipment to separate material of two liquid types not to be able to mix through a method of deposition or stabilization in a process to extract solvent in a petrochemical plant or in a process to refine petroleum in the refinery plant

JFC can supply, manufacture and design **Coalescer/Separator** to guarantee optimum performance from customer requirement and accumulated Know-How that is based on an experience of production and design for many years

There are following some kinds of **Coalescer/Separator** according to material to want to separate or fluid to be applied

- 1) Liquid/Liquid Coalescer
- 2) Liquid/Gas Coalescer
- 3) Oily Water Separator

It is possible to manufacture **Vane Type, Cartridge Type, Pad Type, Double Stage, Single Stage, Horizontal Type and Vertical Type** according to shape or arrangement of element to be used.

Feature of JFC Coalescer/Separator

- 1) Low Pressure Drop
- 2) Various applicable range
- 3) Complete separation
- 4) Compact Design
- 5) Simple and easy Maintenance

Liquid-Liquid Coalescer

LLC Series

Design of JFC coalescers utilize the latest technology to bring clients the best liquid-liquid coalescer that separate a wide range of two immiscible liquids. Products that are emulsified and hazy are very difficult to separate. They require a specific coalescer design. JFC has the latest solution for even the most difficult to separate applications.

More stringent environmental compliance by governments around the world forces the industry to seek the help of liquid-liquid coalescing technology.

Radial flow coalescers are the latest technology available to JFC. They allow JFC Eng. to design high capacity applications while the vessel size remains small. Radial flow coalescers are also the preferred choice when retrofitting existing liquid-liquid separators for up to 100% more capacity and or improved efficiency.

JFC can design and manufacture coalescer internals, coalescer vessel and the complete skid mounted 2 or 3 phase coalesce systems. JFC can provide efficiencies of <15ppm of free water in oil or free oil in water. JFC can provide instead of a dual pre-filter coalescer vessel system to protect the coalescer pack from plugging, a CPI coalescer or Plate Pack Coalescer. The CPI coalescer will remove solids greater than 10microns and is installed in that same coalescer vessel, which is a more cost effective solution.

BENEFITS

- 1) Reduces cost due to smaller vessel design
- 2) Capacity increase for the existing vessels
- 3) Higher recovery of valuable products
- 4) Removal of haziness in the product
- 5) Reduces blending delays
- 6) Reduces wastewater production from tankage, separator and desalter

* JFC can also offer calming baffles, sand jet removal systems

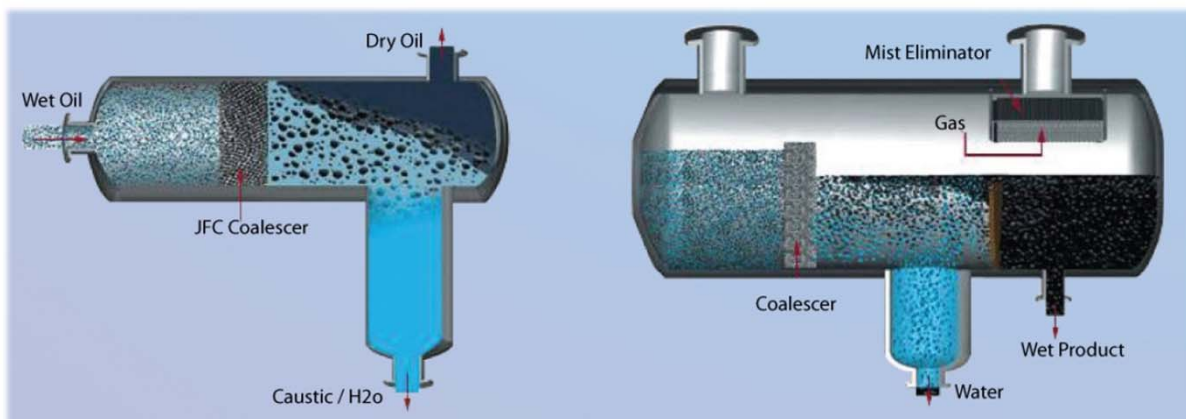

Filter Separator

GLF Series

JFC two stage filter separator technology allows you to have the smallest possible vessel diameter, resulting in the lowest cost while removing aerosol liquids and solid particles efficiently.

The first stage contains replaceable coalescing filters mounted on a tube sheet. Here the bulk liquids and solids are removed while coalescing the aerosol liquid droplets into large ones (greater than 10 microns). Some of these coalesced droplets fall off the filter but the majority is pushed to the second stage due to the high surface velocity. In the second stage, these large droplets are removed by a high capacity Double Pocket Vane.

Filter separators can be designed both vertically and horizontally.

BENEFITS

- 1) Removes aerosol mist to protect downstream equipment from damage, fouling, pitting corrosion or deactivating of catalyst or molecular sieves.
- 2) Reduces amine or glycol foaming problem by removing solids and free liquid particles from the inlet gas stream
- 3) Allow low cost vessel designs
- 4) Debottleneck existing equipment, and adding up to 100% more capacity without requiring a new separator
- 5) Protects ultra low NOx burners from plugging, therefore preventing furnace heat imbalance

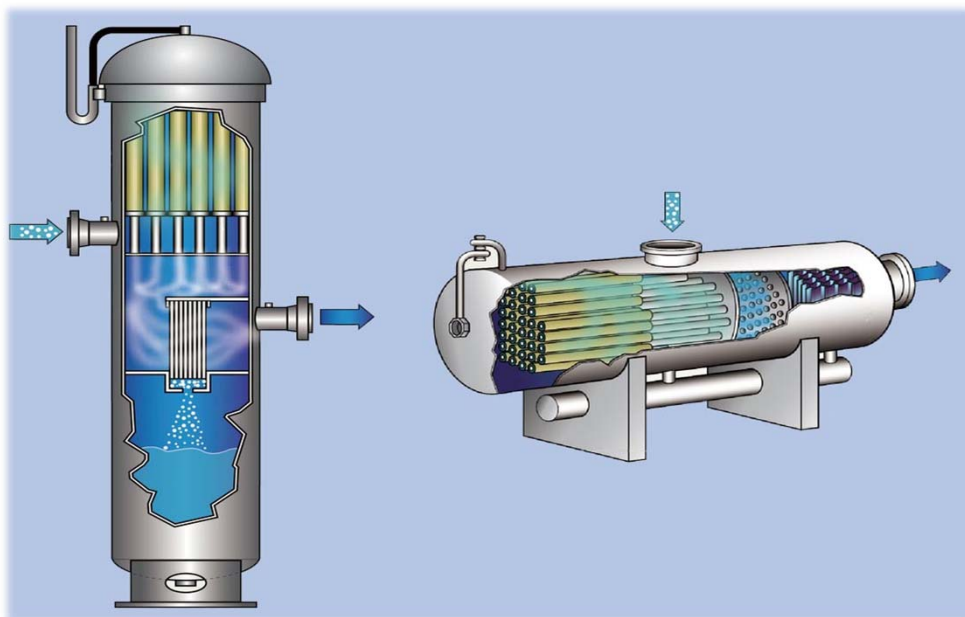

MIST ELIMINATOR

JFC Corporation

Mesh Type Mist Eliminator

MME Series

JFC provides high performance Mesh Type Mist Eliminators versus the standard units that many companies supply. In today's demanding market standard, Mesh Mist Eliminators cannot meet the stringent requirements like higher capacity, better efficiency and lower pressure drop. For every new application, upgrade of debottlenecking such help is a must to make the most of your mist eliminator investment. Since the variables involved in specifying mesh mist eliminators are numerous the client should consult with JFC engineers before making a final selection.

The most widely used standard type of mesh mist eliminator is the 144 kg/m³ density made of metal and using a 0.028 wire. The knitted mesh is crimped and layer (alternate directions) to form a 100mm or 150mm thick unit. The rigidity is provided by a top and bottom grid structure welded together. Pads that are 914mm and larger are fabricated in narrow sections, enough to pass through a manway for assembly inside the separator. Recent advances in technology has brought mist eliminator designs and application expertise to new levels.

BENEFITS

- 1) Increases separator throughput or reduce size of new separators.
- 2) Improves product purity and reduce environmental pollution
- 3) Reduces operation cost
- 4) Increases recovery of valuable liquids and therefore reduce downstream corrosion

With the more advanced mesh mist eliminators it is critical for the design of the mist eliminator that you consider; vessel layout, proper gas distribution, location of inlet/outlet nozzle, liquid holding capacity and method of liquid drainage so the mesh pad will function efficiently.

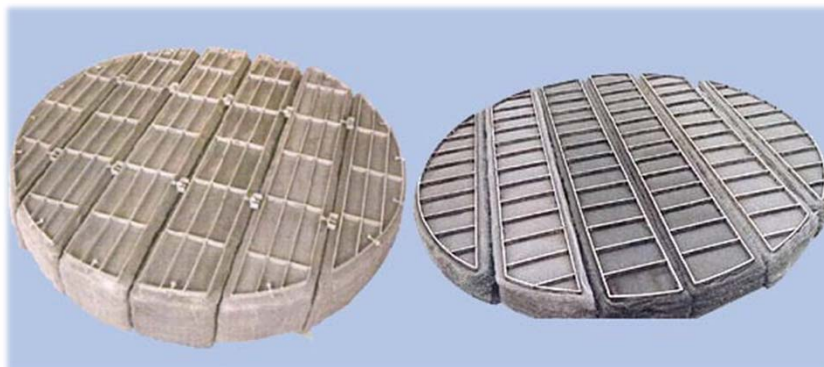

Standard Vane

STV Series

JFC manufactures all type of vane packs also known as Chevron vane mist eliminators. Vane consist of closely spaced corrugated plates that force the mist laden gas to follow the corrugated path. As the gas changes direction, the mist droplet momentum forces it to impact on the blades and coalesces to larger droplet and eventually drains off the blades. Vane packs are normally not efficient for mist droplets less than 20microns. However vanes are sturdier than mesh mist eliminators, provide a lower pressure drop and are less likely to plug. Vane blade spacing varies from 12 to 75mm depending on the dirt/solid loading. Vanes are available in all types of metal and plastic.

BENEFITS

- 1) Higher capacity than standard mesh mist eliminators
- 2) Lower pressure drop
- 3) Handles viscous or foaming liquids more efficiently
- 4) Dissipates slugs of liquid or high liquid mist loading
- 5) Resistant against violent upsets
- 6) Handles solids with minimal chance of plugging

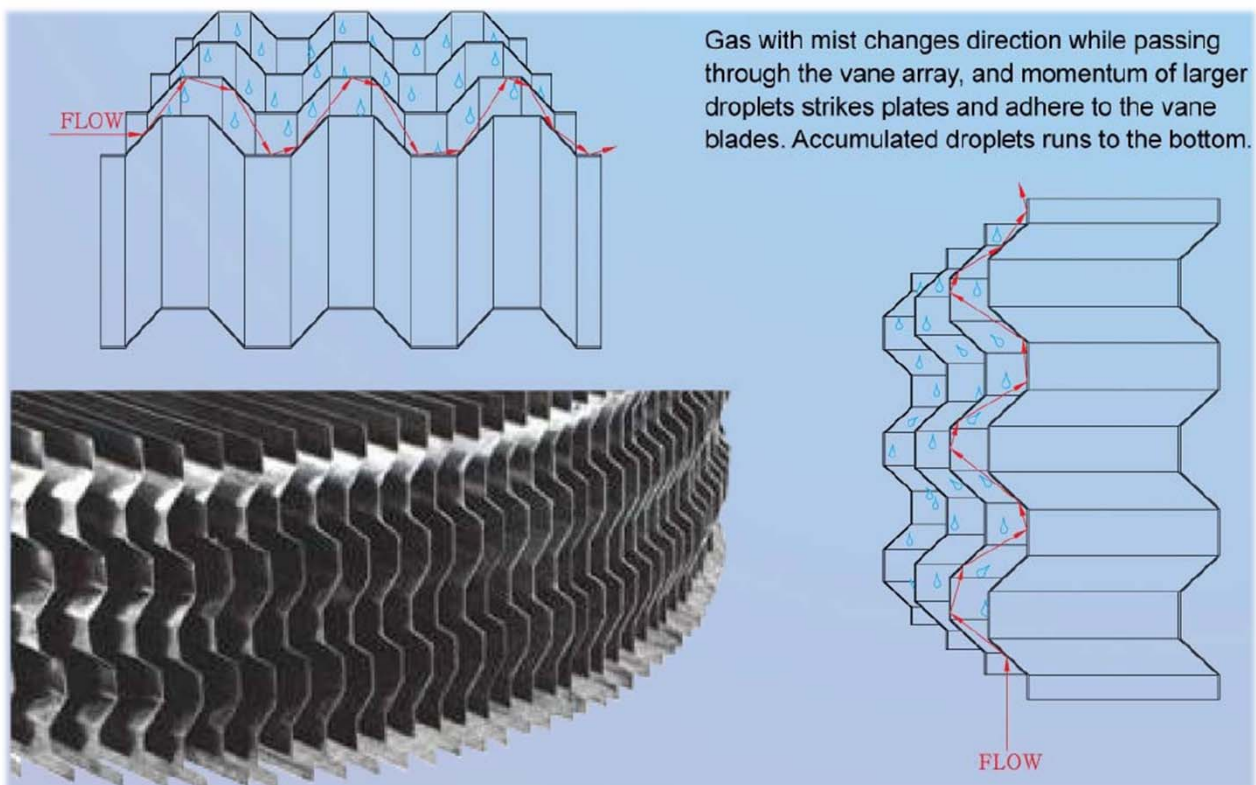

Double Pocket Vane

DPV Series

To increase capacity on an existing separator or to reduce size of a new vessel, JFC's Double Pocket Vane technology can be the answer. The unique geometry of this vane removes the collected liquids away from the gas. This design feature allows for twice the gas flow through the Double Pocket Vane versus a Standard Vane without any concern of liquid re-entrainment. The blade geometry in addition allows more efficient mist removal than the standard vane. In applications where a mesh type mist eliminator would plug due to the presence of solids, waxes or paraffin. Double Pocket Vanes are the preferred solution. The Double Pocket Vane is plugging resistant and has the efficiency of a mesh mist eliminator. Double Pocket Vanes are also the preferred technology with applications that require a smaller vessel foot print or a vessel with limited weight allowance. Double Pocket Vanes can be supplied in any types of metals.

BENEFITS

- 1) Increases capacity up to 100%
- 2) Reduces size and weight for new vessel, resulting in reduced cost
- 3) Increases efficiency versus standard vanes
- 4) Debottleneck existing separators for capacity and efficiency

Type	ST Vane Vertical	ST Vane Horizontal	DP Vane	Mesh Pad
Capacity	K=0.45	K=0.65	K=1.2	K=0.35 (<100psi)
Efficiency	99%> 20microns	99%> 20microns	99.9% 8microns	99.9% 10microns

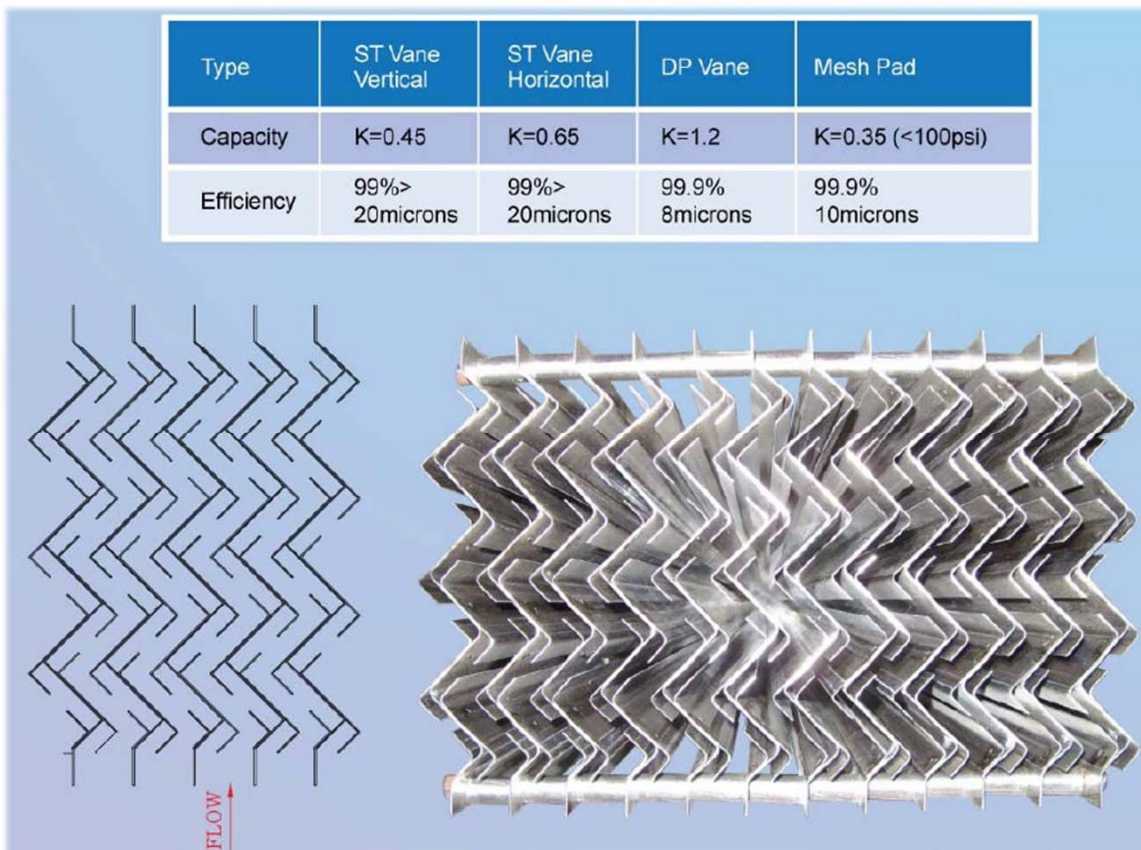

Inlet Diffuser

EQF Series

Utilizing Inlet Diffusers are often overlooked, but yet an important device for designing efficient separators for the industry. JFC's Inlet Diffuser, "Equal Flow" (EQF model) is designed to provide the latest technology to enhance the capacity and efficiency of separators 2~3 phases and for horizontal and vertical. Equal Flow can be manufactured with any type of metal.

BENEFITS

- 1) Removes high liquid loads from the incoming gas improving the downstream separation equipment efficiency
- 2) Dissipates high inlet gas velocities efficiently, avoiding localized high velocities
- 3) Evenly distributes the gas flow throughout the separator with minimal pressure drop
- 4) Prevents inlet gas to get into the bottom liquid level and re-entrain additional liquid droplets
potentially flooding the downstream mist eliminator
- 5) Reduces vessel height or length
- 6) Allows higher gas flow in a smaller separator without creating localized channeling with intern caused liquid carry at the downstream mist elimination equipment
- 7) Removes mild foaming if present at the inlet gas

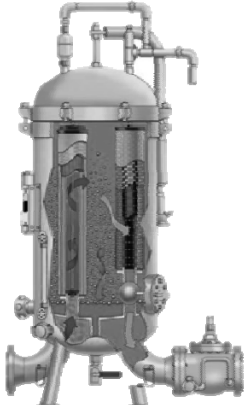
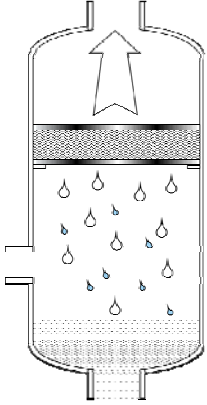
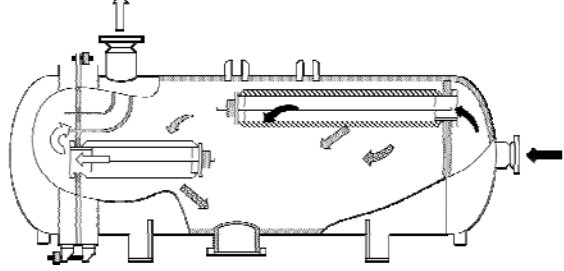
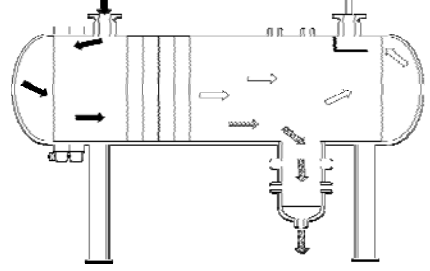
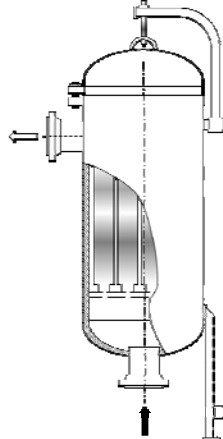
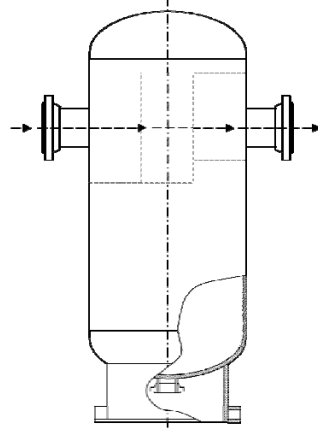
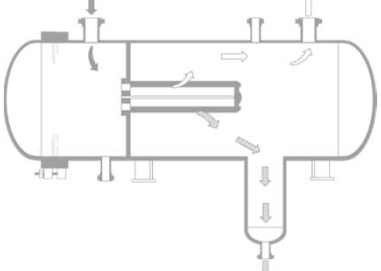
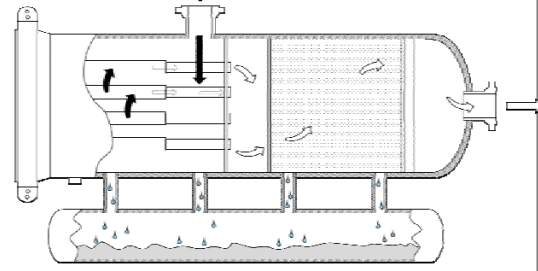

JFC Coalescer / Separator / Filter Housing type

<p>JC1</p>	<p>Vertical Type, Two Stage Cartridge</p>	<p>JC5</p>	<p>Vertical Type, Pad Type</p>
			
<p>JC2</p>	<p>Horizontal Type, Cartridge</p>	<p>JC6</p>	<p>Horizontal Type, Pad Type</p>
			
<p>JC3</p>	<p>Vertical Type, Single Stage Cartridge</p>	<p>JC7</p>	<p>Vertical Type, Vane Type</p>
			
<p>JC4</p>	<p>Horizontal Type, Single Cartridge</p>	<p>JC8</p>	<p>Horizontal Type, Vane & Cartridge Type</p>
			

FILTER SYSTEM

JFC Corporation

Activated Carbon / Anthracite Filter System

JW-Type

It is Reverse Washing Type of Filtration System to use jointly physical absorption and a heap filter to insert a carbon or anthracite. In case of liquid phase, mainly it is used to clean water treatment.

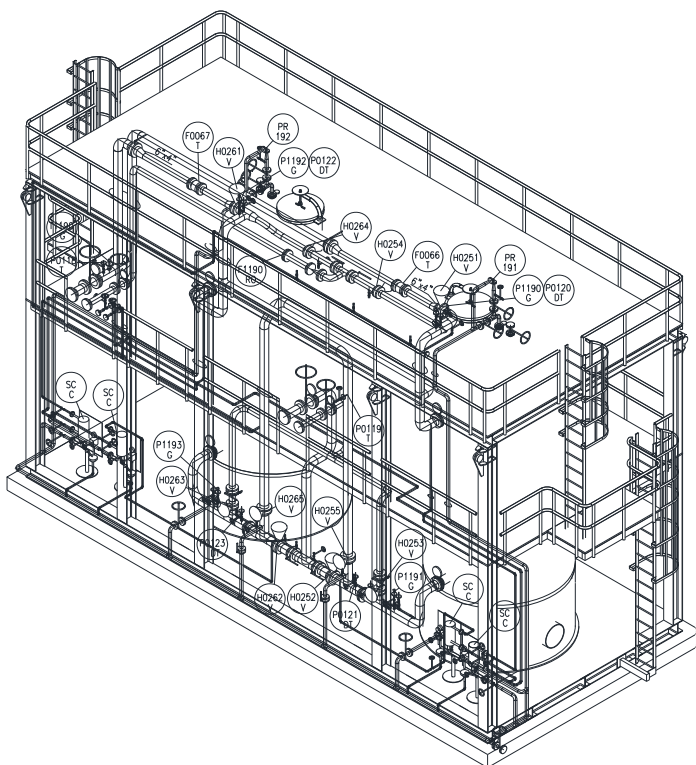

In case of gas, it is utilized to remove an organic gas or bad material and is mainly a fixed bed type

Application

1. Liquid Filtration

- Removes smell, taste, chlorine and iron of drink water
- Refines water to make a soft drink or brewing, water to use in a boiler and industrial water.
- Filtration of amine and glycol

2. Gas Filtration

- Purifies hydrogen, carbonic acid gas, chloride gas and other inorganic gas
- Purifies ethylene, acetylene, and other gas about petrochemical
- Purifies gas for chemical industry exhaust
- Removes radiation elements of exhaust of a pile and desulfurizes a combustion exhaust
- It is possible to remove a chemical action gas if using a special filler of alkali metals

Auto Control Filter System

Porous Metal Blowback Filter System for Gaseous Service

Porous Metal Backwash Filter System for Liquid Service

- High Solids Recovery
It has a high performance to capture over 99.999% of the solids to be critical or hazardous or valuable
- High Temperature Operation
It endures to a temperature to 1700 °F (927 °C)
- Automated Operation
It is fully automated system to be able to discharge solids periodically
- Low Replacement Costs
JFC Precision Metal Filter Element is a permanent self-supporting system which process a consistent performance
- Long lasting Life time
Downtime to wash is not necessary as it is washed by Blowback or Backwash based on the Venturi Pulse System

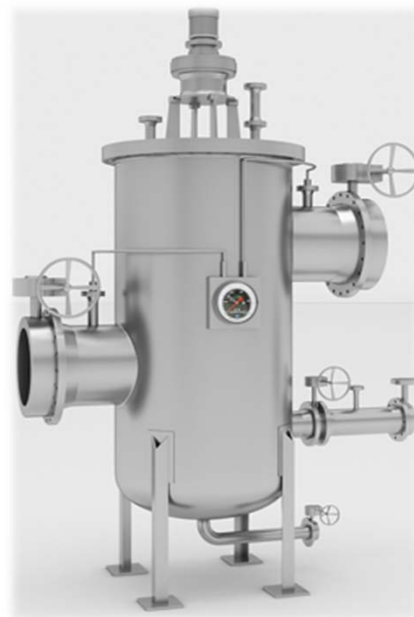

Application of Blowback / Backwash System

Gaseous Service

- Remove Solid particles in various gas steams to cover wide industries
- Catalyst Retention or Radioactive Waste Removal Performance is very excellent in wide industries to cover Nuclear Industry or Chemical Industry

Liquid Service

- Excellent Catalyst Retention from various Liquids
- Excellent Performance to remove Solid Particles from a liquid flow
- Excellent Filtration of a Polymer to have high viscosity

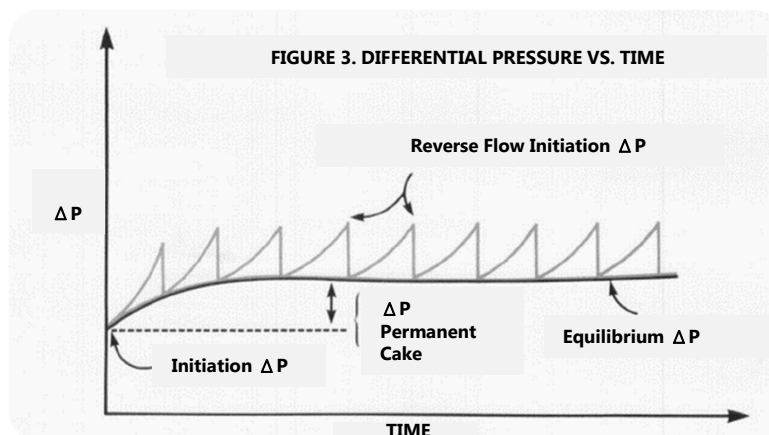
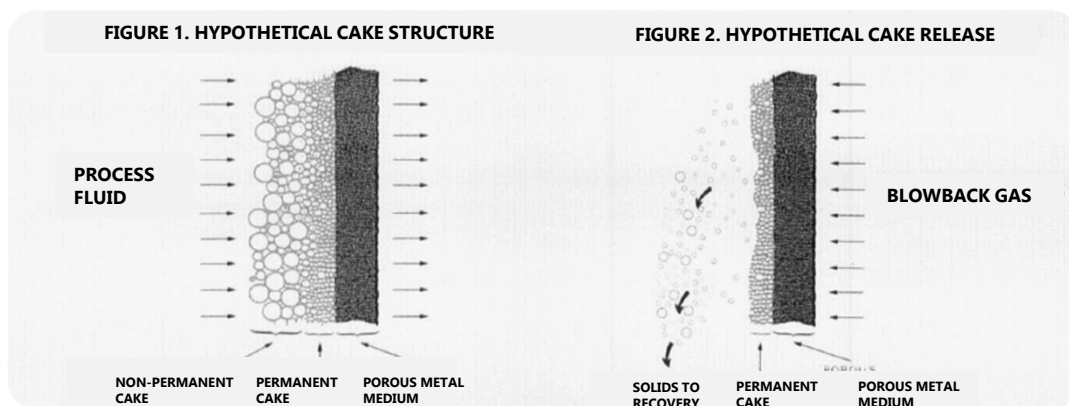

Auto Strainer

JA-B Type Brush Wash Type

It is possible to operate continuous with a simple instrumentation

- It is advantageous to a fluid of a high viscosity with mechanical washing method
- Retention capacity of particle pollution, flow loss is low
- Choice operation by a timer or by a switch for pressure drop is possible as Automatic Operation System
- To repair and maintain is convenient, as it is an open and shut system to have installed a bottom cover

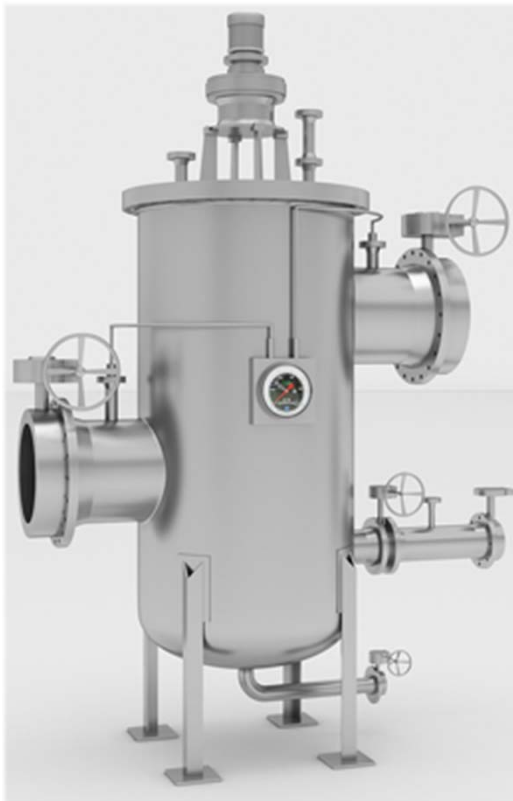

JA-R Type Backwash Type

Continuous operation is possible

- Filter granularity is delicate relatively comparing JA-B, as it is backwash system to utilize operation pressure
- It is advantageous when an condition of pressure drop is high as an element has a small bore and pressure resistance is good
- Choice operation by a timer or by a switch for pressure drop is possible as Automatic Operation System

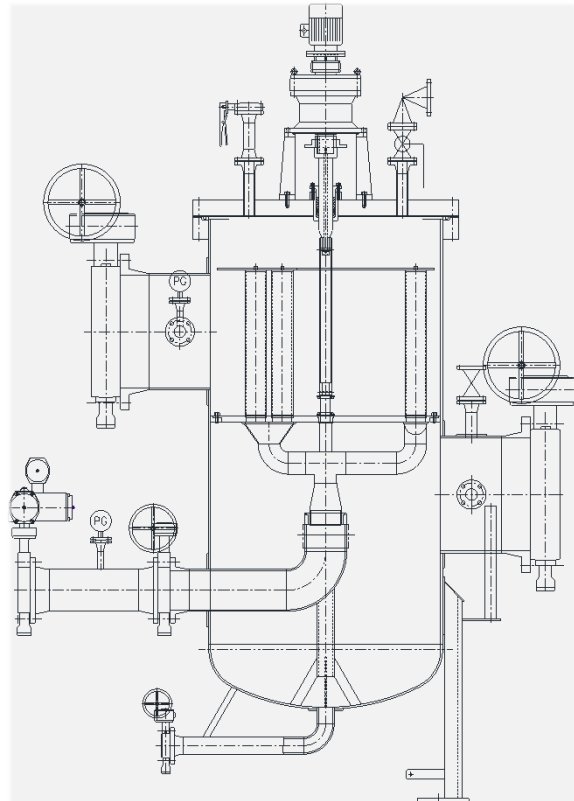

Auto Strainer

JA-B Type

- Chemical Industry area
 - Chemical industry, Synthetic resin, pigment, paint, rubber, natural oil, oil refinery industry and etc.
- Other Industry Area
 - Cutting oil, paper coloring and breaching, bottle washing, removal of fat of wool and etc.
- Clean Water Treatment Area
 - Water Supply Facilities, Sewage Treatment Plant, Well and etc.

JA-R Type

- Clean Water Treatment Area
 - Waterworks Treatment Plant, Sewage Treatment Plant, Well, Boiler Water, Cooling Water, Waste Use in industry
- Industry Area of Fuel and Lubricating Oil
 - Lubrication oil, Natural oil, Gasoline, Diesel, Kerosene etc.
- Chemistry Solvent Area

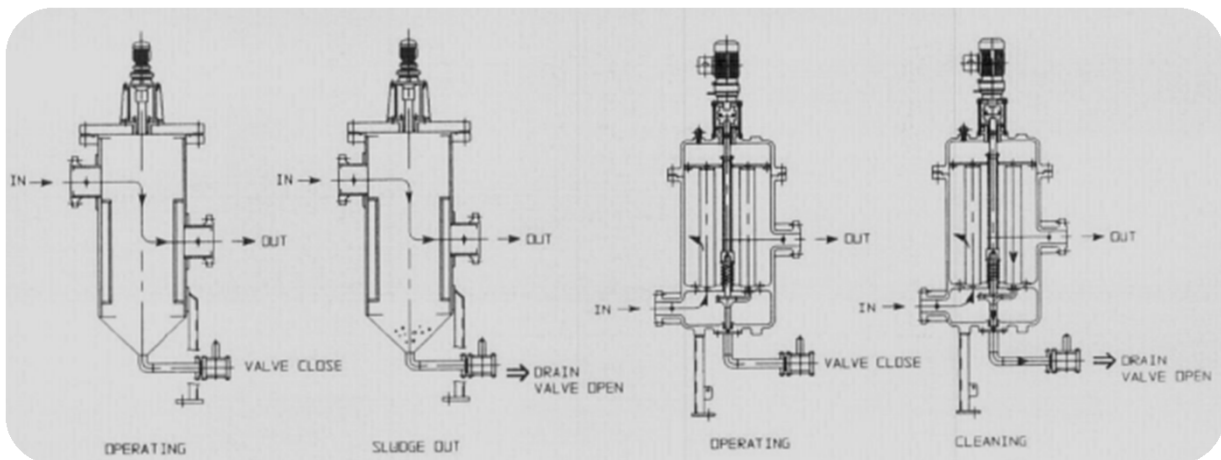

Type	Perforated Plate		Wedge Wire (Triangle Section Wire)		Mesh Screen	
			Horizontal	Vertical	Normal	Special
Structure						
	Round hole Min. dia. 0.25mm (250 Micron)	Long hole slit Min. width 0.02mm (20 Micron)	Slot opening Min. 0.025mm (25 Micron)	Slot opening Min. 0.025mm (25 Micron)	Flat weave Straw mat weave	Multi-layer
Use	Mainly Preliminary filtration		Micron filtration suitable for back washing		Recommended for contaminants effective to precoating or for back-wash only	

STRAINER

JFC Corporation

Strainer

JFC Strainer

JFC Strainer is used widely to fluid and gas such as water, oil, air, gas in each field of Oil Refinery, Petrochemical Plant, Waterworks, Power Plant, Iron Manufacturing, Ship-building, Paper Manufacturing, Synthetic Fiber

Material of JFC Strainer

Carbon Steel

- ASME : A105, A216, A53, A234, A106, A516

Stainless Steel

- 304SS, 304LSS, 316SS, 316LSS

Alloy Steel and Special Steel

- Monel, Hastelloy, Aluminum, Bronze, Copper Alloy, Chrome Alloy, Nickel Alloy and etc.

Strainer Element

Elements is very important part as the heart of strainer. So, Corrosion Resistance, Filtration rate and Strength must be considered sufficiently and it must be a structure not to be bypassed the non-filtered fluid between element and body. JFC is manufacturing a high credible strainer that can't compare with other production as it has a long experience and accumulated know-how in field of engineering

Connection Style

Flange Type / Socket Weld Type / Screw Type (PT,NPT) / Butt Weld Type

Applicable Code

ASME / DIN / BS / ISO / MSS / API



Strainer Performance

The Performance of Strainer is various and the summary is as followings :

1. Normally used for the protection of pipeline and petroleum process equipment installed downstream of strainers.
2. Filtration resistance of strainer shall be minimum. Specially, urgent filtration resistance shall not increase even after some using period passed.
 - There is no problem as the absolute value of initial pressure drop in filtration resistance is small. But till a pressure drop reaches the maximum value, the filtration resistance is influenced by time of washing cycle.
3. Must be a structure to be maintained airtightness between a contacting part of element and a parallel state of strainer.
4. Element and Strainer Body shall be endurable in the high-pressure-drop against internal, external pressure sufficiently

JFC Strainer is designed by the basis of the above requisition and JFC has a long experienced know-how and a lot of customers are recognizing the quality of the excellent strainer in domestic and oversea petrochemical and refinery project for long years from Super Low Temperature -196°C of the Ethylene Process till 350°C , a temperature of Heavy Grade Oil Resolution Facilities and the high pressure of 2500 pound basis.

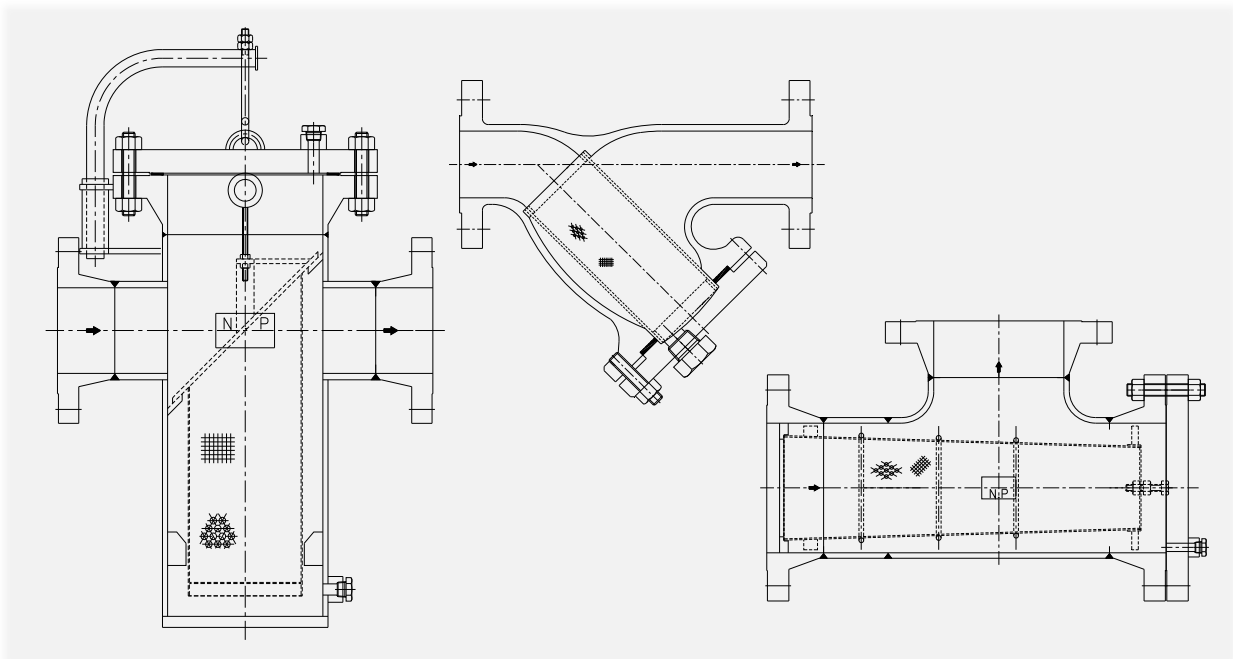

JS-B Strainer

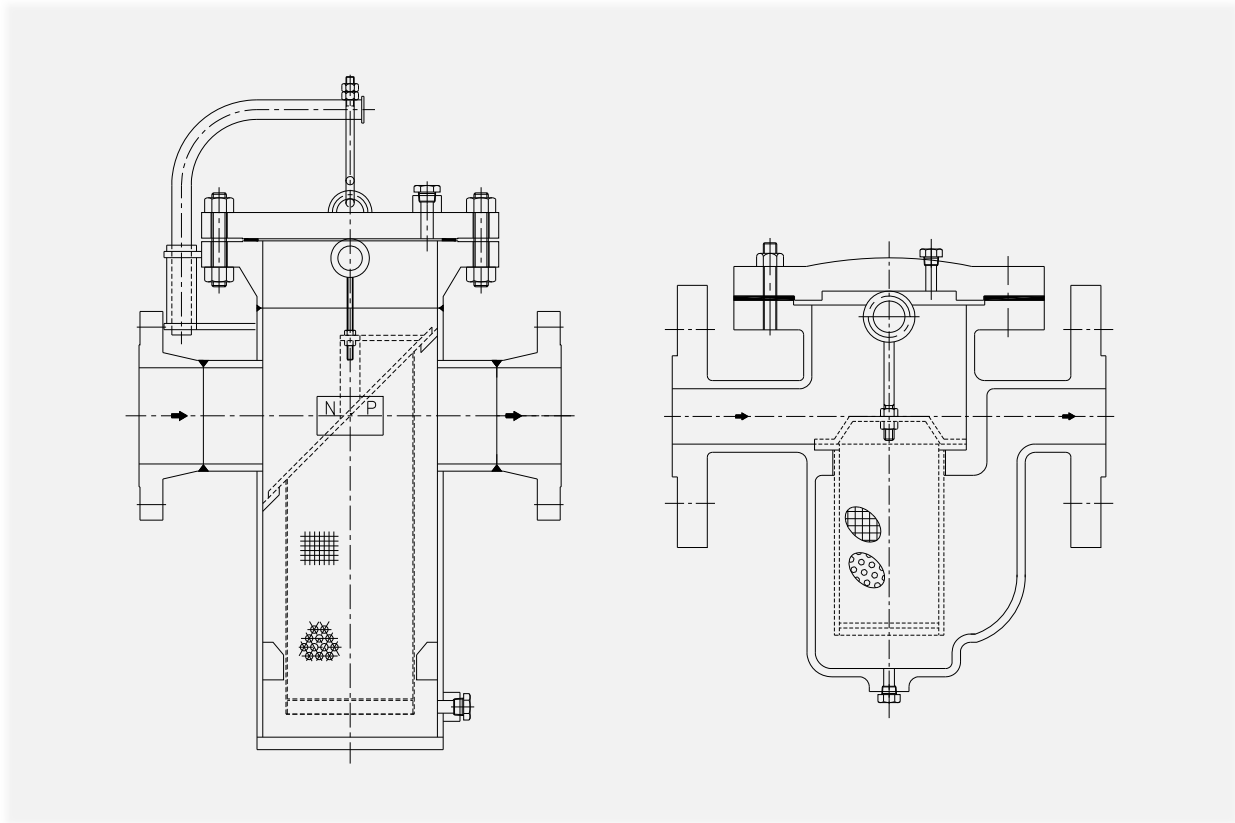

JS-B type strainers are used where the line can be shut down for short periods to clean or change baskets. And they are designed for installation in horizontal lines. They are commonly used for liquid service applications. JS-B type strainers are generally used where high flow capacity is required.

Unlike other types of strainer, the basket is removed and replaced through the top of the strainer body which prevents the spilling of liquid during the servicing of the strainer screen. Standard basket screen material is stainless steel. Standard screens are available from 1/4" (perforated) up to 100 mesh.

JS-Y Strainer

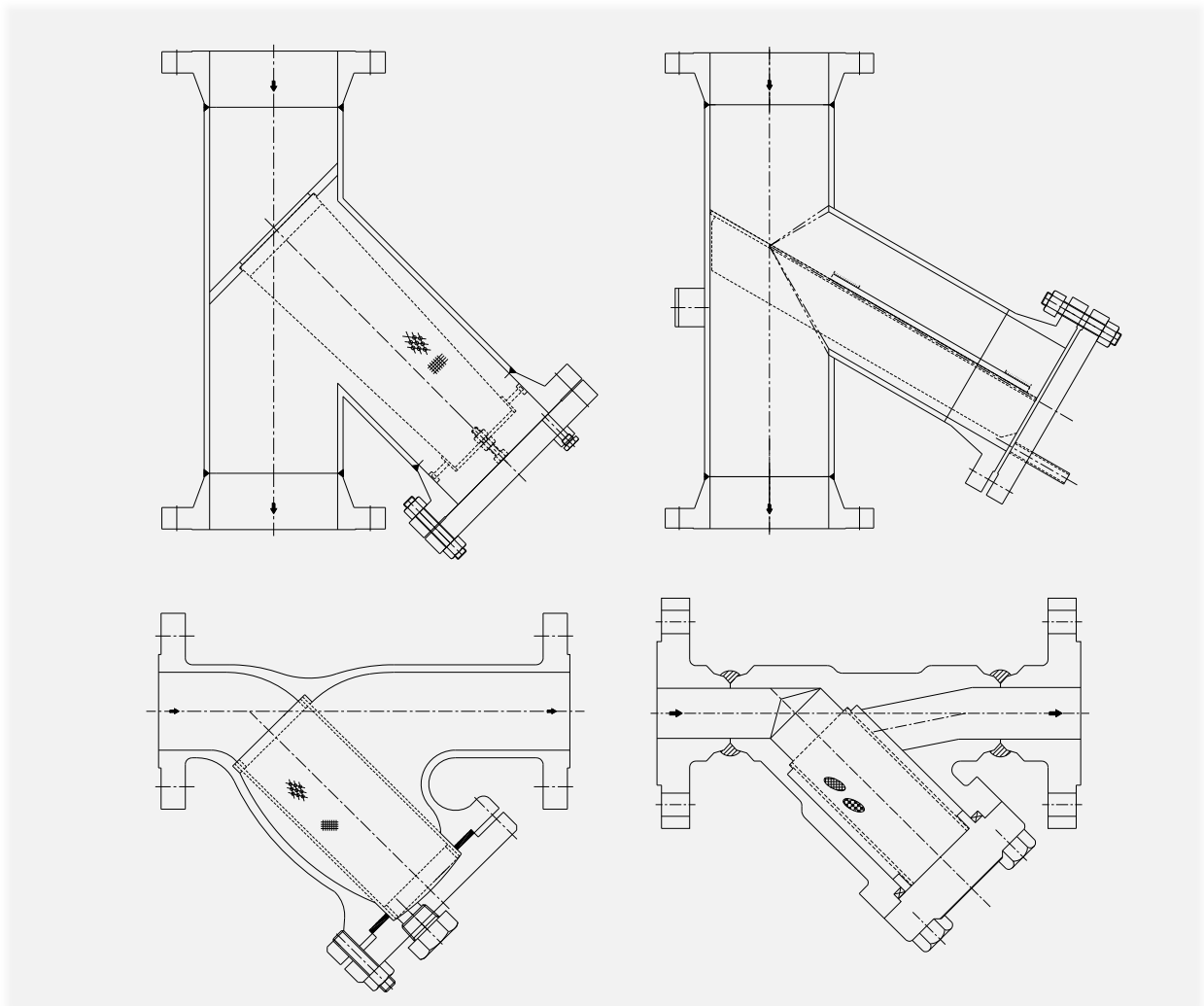

JS-Y Type Strainers are named after their shape and normally used for course filtration. But with large filtration area can be used with fine mesh also. The Strainer improves the clearance in the medium and prolongs the life of valves; protect expensive pumps, meters and other equipment. It is suitable for water, air, gas, petroleum, steam and other fluids.

A JS-Y type strainer can be installed in either a horizontal or vertical position (Downward flow) with the screen element pointing downward. This allows the strainer screen to collect material in the strainer at the lowest point of the screen.

JS-T Strainer

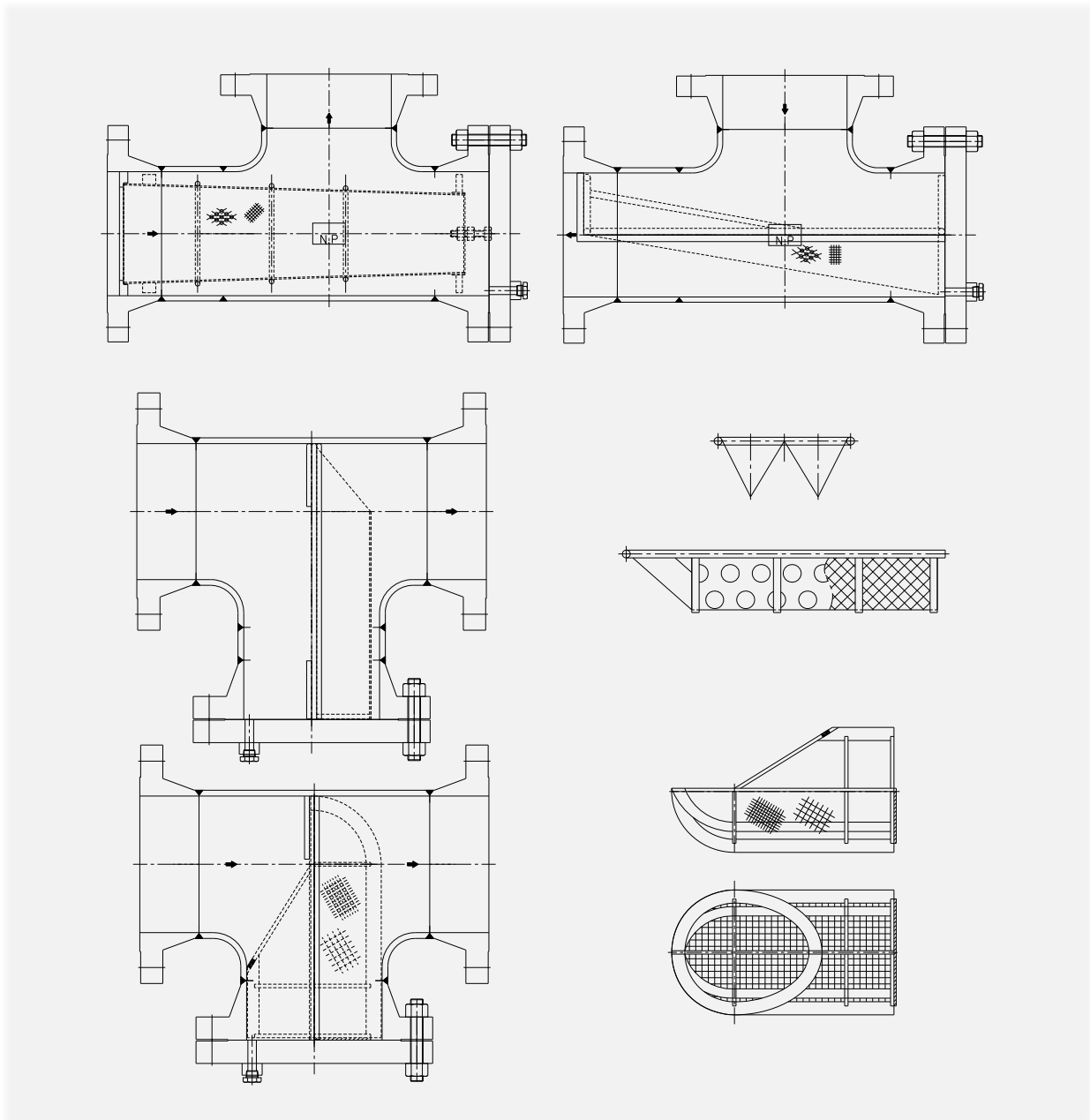

JS-T type strainer is very compact, important in applications where space is restricted. Unlike most other strainers JS-T type strainer can be used in both vertical or horizontal installations. JS-T type strainer can also be adapted for straight through or right angle flow.

JFC has advantages bending and cylindrical type element applied to improve the efficiency of JS-T type strainer.

JS-C (Temporary) Strainer

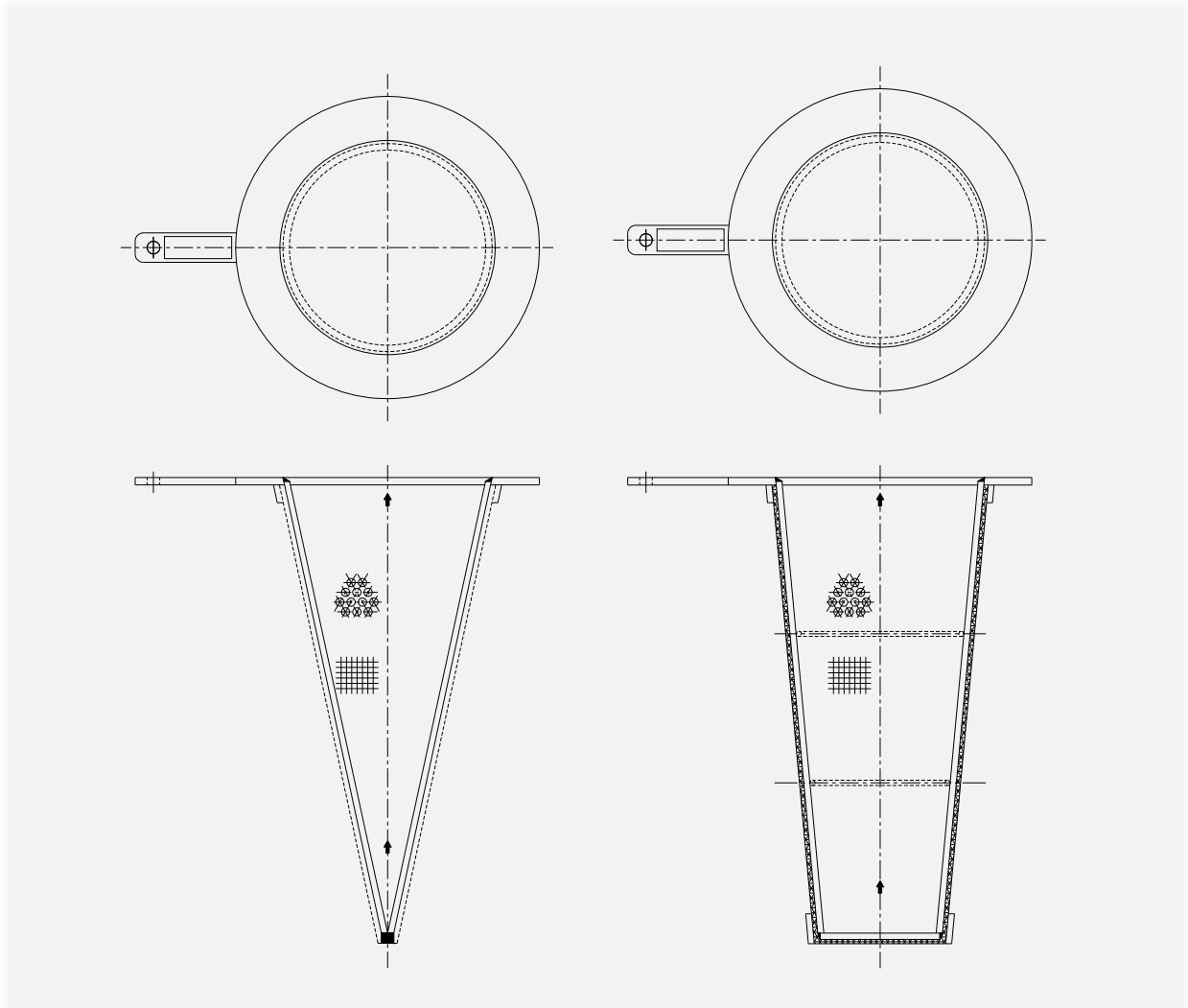

JS-C type strainer are used for start-up of new or revamped piping systems. They will prevent construction debris from causing damage to downstream equipment. The screen is tig welded around entire circumference of the flange ring to provide and prevent unwanted bypass.

JS-D Strainer

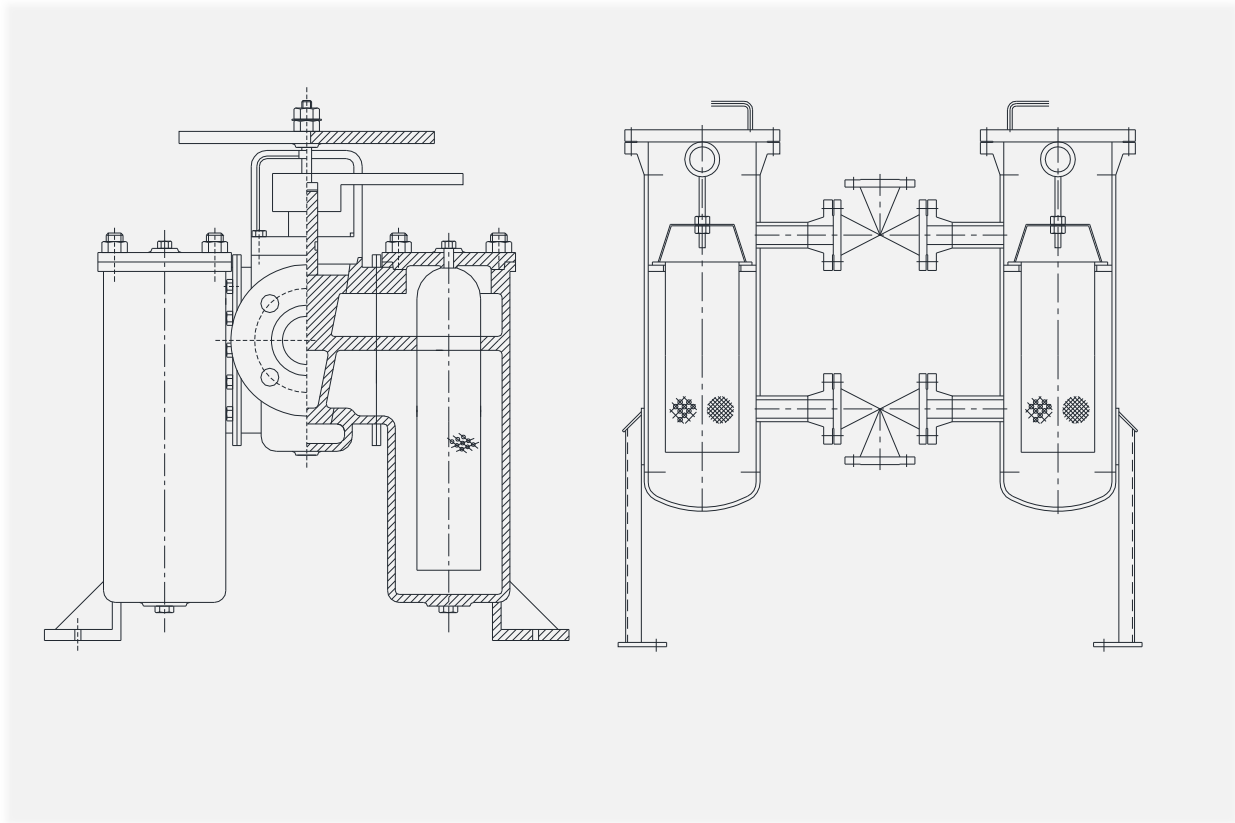

It is a strainer that is designed in order to operate continuous while cleaning the internal element as Duplex Strainer that two strainers connected in a row can convert a flow direction by a valve operation.

In case of a common Duplex Strainer. It can be operated with continuous fluid flow because valve of inlet side and outlet side must be connected.

But JS-D type install the 3-way Check Valve in outlet side and a control valve in inlet side. And it is a system that 3-way Check Valve in outlet side converts the fluid direction automatically by the difference of an internal pressure as soon as operating the converting control valve.

Standard Screen Micrometer Conversion Chart

US and ASTM STD. Sieve Number	Actual Opening	
	Inches	Micrometers
10	0.0787	2000
12	0.0661	1680
14	0.0555	1410
16	0.0469	1190
18	0.0394	1000
20	0.0331	840
25	0.0280	710
30	0.0232	590
35	0.0197	500
40	0.0165	420
45	0.0138	350
50	0.0117	297
60	0.0098	250
70	0.0083	210
80	0.0070	177
100	0.0059	149
120	0.0049	125
140	0.0041	105
170	0.0035	88
200	0.0029	74
230	0.0024	62
270	0.0021	53
325	0.0017	44
400	0.00142	36
550	0.00099	25
625	0.00079	20
1,250	0.000394	10
1,750	0.000315	8
2,500	0.000197	5
5,000	0.000099	2.5
12,000	0.0000394	1

Micrometer Comparisons	
Substance	Micrometers
Table Salt	100
Human Hair (AVG.)	50-70
White blood cell	25
Talcum powder 10	10
Cocoa	8-10
Red Blood Cell	8
Bacteria (cocci)	2

Note. Lower limit of visibility (naked eye) – 40 micrometers

Relative Size of Particles

Magnification 500 times

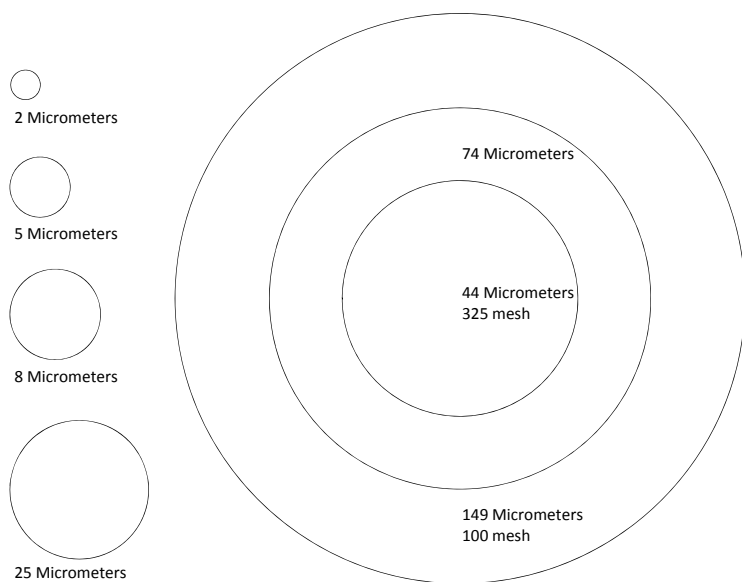

Linear Equivalents

1 inch	=	25.4 millimeters	=	25,400 micrometers
1 millimeter	=	0.0394 inches	=	1,000 micrometers
1 micrometer	=	$\frac{1}{25.400}$ of an inch	=	0.001 millimeters
1 micrometer	=	3.94×10^{-5} inches	=	0.000039 inches

Formulas

$$\text{velocity (ft. per sec.)} = \frac{0.4085 \times \text{gpm}}{d^2 \text{ (id in.)}}$$

$$\text{brake h.p.} = \frac{(\text{gpm}) \times (\text{total head in ft.}) \times (\text{specific gravity})}{(3960) \times (\text{pump efficiency})}$$

Conversion Rates

1 cu. ft	=	7.48 gal.
1 ga.	=	231 cu.in.
1cu.ft. water	=	62.42 lb.
1 gal. water	=	8.34 lb.
1 lb. water	=	27.7 cu.in.
1 U.S. gal.	=	0.833 Imp. gal.
1 lb./in ²	=	2.31 ft. of water=2.2036 in. HG.
°F	=	9/5°C + 32

Metric Conversion Formulas

mm	=	inches x 25.4
m	=	feet x 0.3048
cm ³	=	cu. in x 16.39
m ³	=	cu. ft. x 0.028
kg	=	pounds x 0.454
kPa	=	psi x 6.895
lpm	=	gpm x 3.785
°C	=	5/9 (°F - 32)

Q & A

JFC Corporation

1318-20 Jangyeo-ro, Jeomdong-myeon, Yeosu-si, Gyeonggi-do, Korea

Tel : +82-2-877-9595(main), +82-31-881-4526

Fax : +82-2-877-0027(main), +82-31-881-4527

E-mail : jfc@jfc.co.kr

Homepage : www.jfc.co.kr